

OIL COOLER MOUNT INTALLATION INSTRUCTIONS

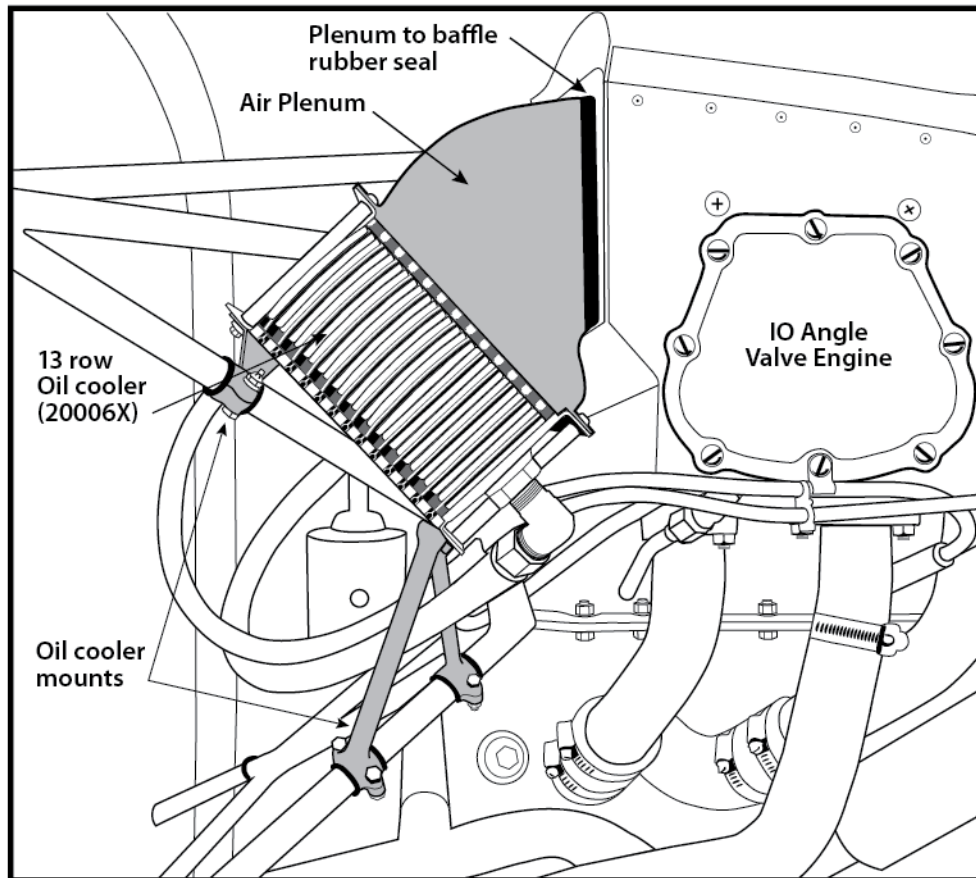

These instructions will guide you through the installation of the oil cooler mount and 20006X or equivalent sized 13 row oil cooler.

(REV A 8/18)

Temporarily attach the upper and lower mounts on the oil cooler using the supplied hardware shown in detail A, trim bushing length as/if needed. Install cooler/mount assembly on the engine mount tubes using clamp halves and rubber channel. Lightly tighten all hardware to allow for position adjustment. Position the cooler/mount assembly parallel to the firewall and level to aircraft plane, built in engine offset will account for an uneven distance from the engine baffle to oil cooler. Make sure no part of the oil cooler interferes with the engine mount tubes.

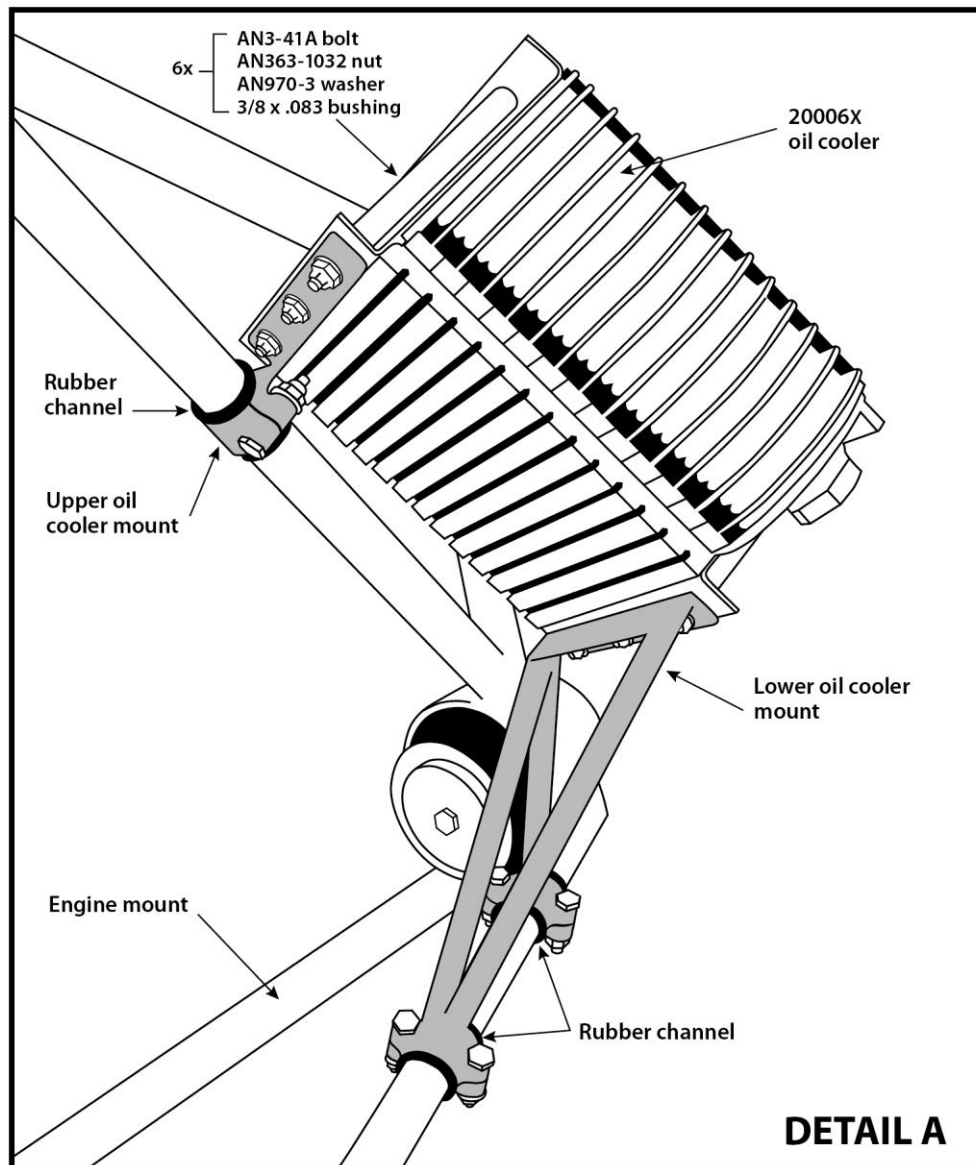

Remove oil cooler leaving the mounts in location. Trim the air plenum as needed to sit flat on oil cooler, now use the cooler to mark then drill the six mounting holes in the plenum, refer to detail B. Fit the cooler/plenum back on the mounts trimming the intake edge of the plenum as necessary to maintain 3/16" clearance from the engine baffle when the oil cooler is bolted to the mounts.

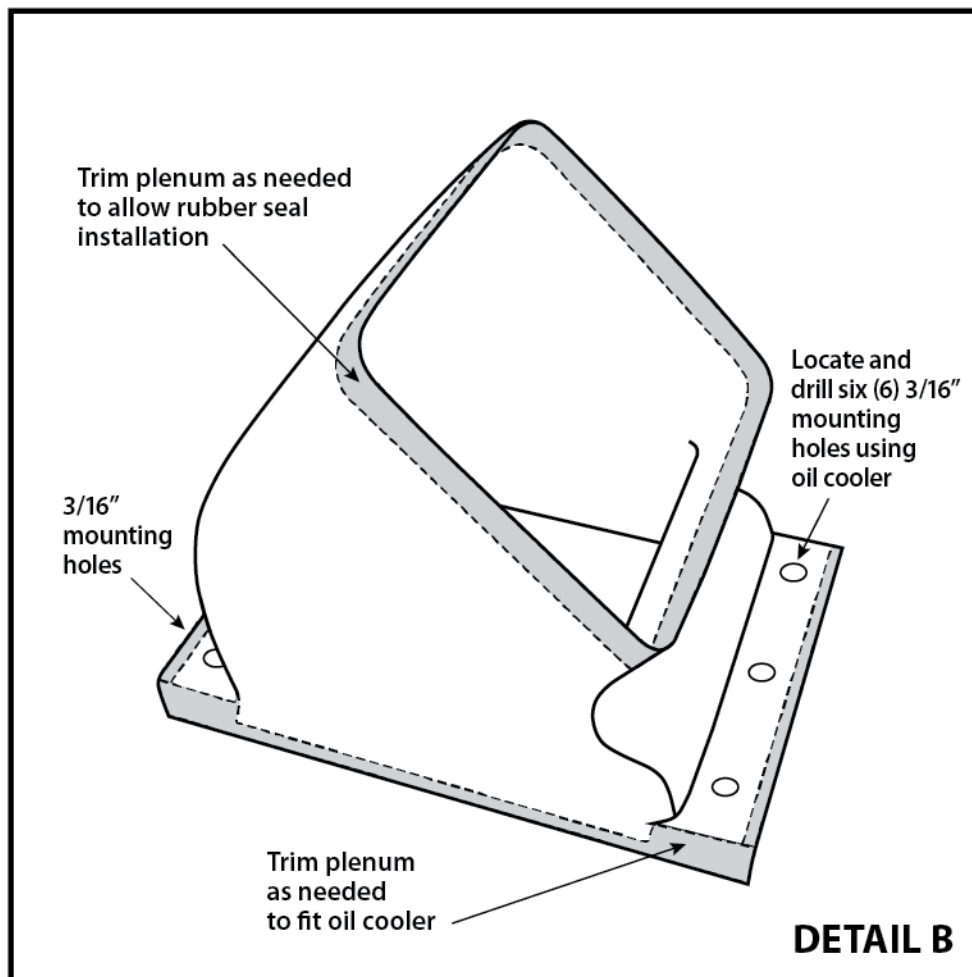

Hold the CB8-7A reinforcement doubler to the engine baffle to locate interfering rivets behind the doubler, remove these rivets that hold the aft and side baffles together. Locate the CB8-7A on the baffle using the air plenum to center it, back drill through engine baffle into doubler and cleco in location. Remove the cooler/plenum and drill the # 30 rivet holes through doubler and baffle as shown in detail C. If the installation is a retrofit a new location for the spark plug wires will have to be found. Dimple countersink all rivet holes that will interfere with the plenum seal, then install the doubler to baffle using 1/8" rivets.

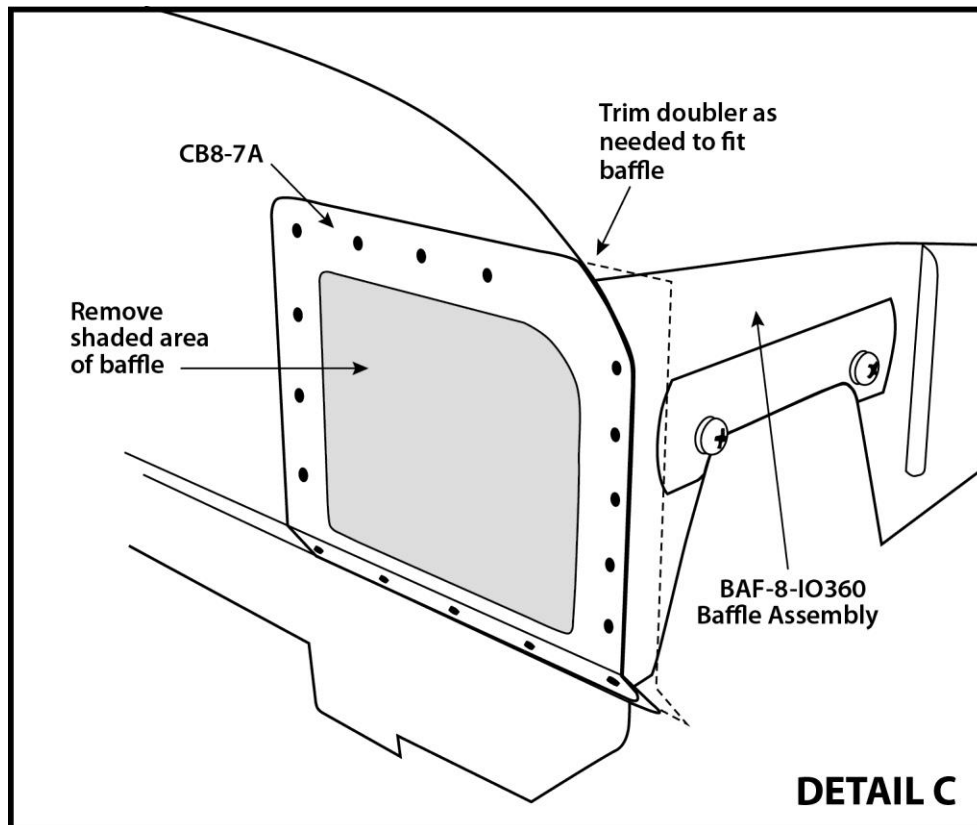

Install seal on air plenum, trim the forward edge of the seal if needed for a relaxed fit. Reinstall cooler/plenum on mounts (*you may want to install hose fittings and fill oil cooler with appropriate oil at this time*). Final torque all cooler/plenum and mount hardware once alignment is correct.

Oil Cooler Mount Packing List

- 1 - OCM-U Upper cooler mount
- 1 - OCM-L Lower cooler mount
- 1 - OCM-PP Air plenum (parallel valve)
- 1 - OCM-PA Air plenum (angle valve)
- 1 - CB-707B Baffle doubler (parallel valve)
- 1 - CB8-7A Baffle doubler (angle valve)
- 1 - OCM-S Plenum seal
- 6 - AN3-11A Bolt
- 6 - AN3-41A Bolt
- 6 - 3/8" X .083 Bushing
- 12 - AN363-1032 Nut
- 12 - AN960-10 Washer